

APPLY LUBRICANT TO ALL SEALS PRIOR TO INSTALLATION. DO NOT USE SILICONE TYPE LUBRICANTS. FOR PROPER ARM MOUNTING SEE IS1505.

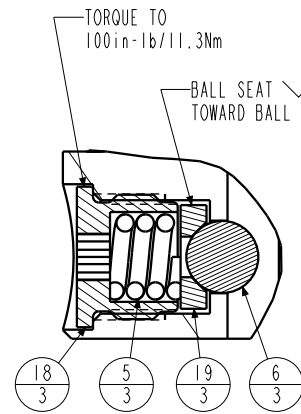

DETAIL A  
SCALE 1.500

N/A	N/A	IS1505	INSTRUCTION SHEET, ARM INSTALLATION		
N/A	N/A	6V711048	SEAL KIT, FKM		
N/A	N/A	60711048	SEAL KIT, STANDARD		
22	1	39V10029	WIPER, PRESS-IN, (1-1/4)	X	X
21	1	81591833	CAM, SC, LP, 5000/22KN, LH, TC, PR		
20	1	81541818	BASE, SC, BF, LP, 5000, PR		
19	3	81532108	SEAT, BALL, SC, LP, TC		
18	3	81532107	RETAINER, SC, LP, TC		
17	1	81500040	RING, LOCATOR, SC, LP, PR		
16	1	39054008	BU RING, (-218)	X	X
15	1	39054007	BU RING, (-030)	X	39054021
14	1	39053005	WIPER, SNAP-IN, (1-1/4)	X	X
13	1	39052043	SEAL, LL, (1/4 X 1/8 X 1/8 X 1/2)	X	39V52043
12	1	39051042	O-RING, (-030)	X	39V01021
11	2	39051041	O-RING, (-006)	X	39051041
10	2	39050042	O-RING, (-011)	X	39051025
9	1	39011060	SEAL, BEVEL WHEEL INSERT, 1-1/4 x 1/8 x 1-1/2	X	39052015
8	1	39011056	SEAL, CROWN, 1-9/16 x 1-3/4 x 5/32	X	39V11056
7	2	30601144	PLUG, SOCH, SAE 4		
6	3	23650004	BALL, TUNGSTEN-CARBIDE. 250		
5	3	23350066	SPRING, COMPRESSION		
4	2	21500200	WASHER		
3	3	21500031	SHCS, M5 x 0.8 x 14, ALY		
2	10	21500023	SHCS, M5 x .8-66 x 30MM		
1	2	21500019	SCREW, CAP, BTM, M3 x 6, ALY		
No.	QTY	PART No.	DESCRIPTION	Std. Seal Kit	FKM Seal Kit

**PARTS LIST**



VEKTEK, INC.  
1334 E. SIXTH AVE. P.O. BOX 625  
EMPORIA, KS. 66801 U.S.A.

ASSEMBLIES AFFECTED

14281801PR

14281801PR

PARTS LIST, ASSY, SC, LP, TC, BF, 5000, DA, LH, PR

SIZE  
A

PL7211

REV  
C

SHEET 1 OF 1

C	5770	RELEASE	JDW	08/02/25
REV	IN ACCORDANCE WITH ECN	EFFECTIVE DATE	REVISED BY	DATE
DRW BY:	JDW	DRAWING STATUS: <b>Released</b>		
DATE:	10/16/13	PRODUCTION APPROVED FOR RELEASED STATUS ONLY		

